

## 8. Quadrilaterals

Q 1 Name a quadrilateral whose each pair of opposite sides is equal.

Mark (1)

Q 2 What is the sum of two consecutive angles in a parallelogram?

Mark (1)

Q 3 The angles of quadrilateral are respectively  $100^\circ$ ,  $30^\circ$ ,  $92^\circ$  and  $x$ . Find the value of  $x$ .

Marks (2)

Q 4 The angles of quadrilateral are in the ratio 3:5:9:13. Find all the angles of the quadrilateral.

Marks (2)

Q 5 The sides AB and CD of a parallelogram ABCD are

bisected at E and F. Prove that EBF D is a parallelogram.

Marks (2)

Q 6 In a triangle ABC, P, Q and R are the mid – points of sides BC, CA and AB respectively.

If AC = 21 cm, BC = 29 cm and AB = 30 cm, find the perimeter of the quadrilateral ARPQ.

Marks (2)

Q 7 Find the four angles P, Q, R and S in the parallelogram PQRS as shown below.

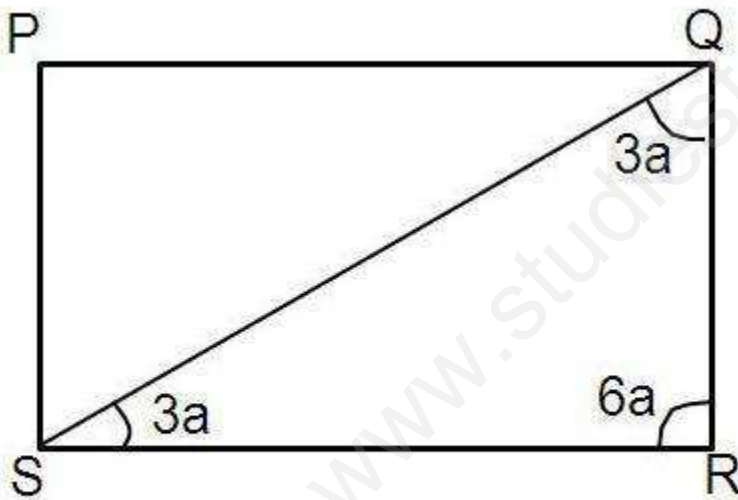

Marks (2)

Q 8 Two opposite angles of a parallelogram are  $(5x + 1)^\circ$  and  $(49 - 3x)^\circ$ .

Find the measure of these opposite angles of the parallelogram.

Marks (2)

Q 9 Prove that each of the four sides of a rhombus is of the same length.

Marks (2)

Q 10 ABCD is a rhombus. Show that diagonals AC bisects angle A as well as angle C.

Marks (2)

Q 11 In the figure given below ,ABCD and PQRC are rectangles and Q is the mid – point of AC. Prove that  $PR = \frac{1}{2} AC$ .

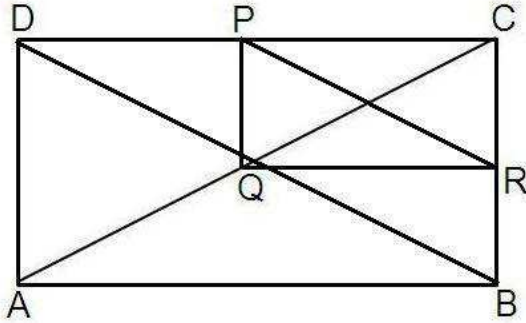

Marks (2)

Q 12 Find the values of  $a$  and also find angles related to  $a$  as shown in the figure.

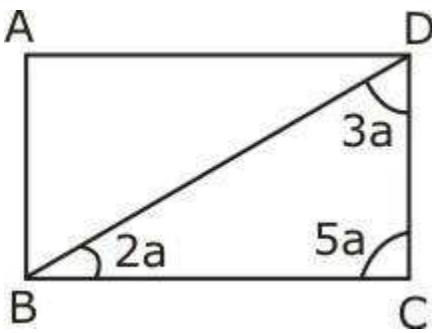

Marks (3)

Q 13 Prove that angle bisectors of a parallelogram form a rectangle.

Marks (3)

Q 14 ABC is an isosceles triangle with  $AB = AC$  and let D, F, E be the mid-points of BC, CA and AB respectively. Show that AD is perpendicular to EF and AD bisects EF.

Marks (3)

Q 15 In a triangle ABC median AD is produced to X such that  $AD = DX$ . Prove that ABXC is a parallelogram.

Marks (3)

Q 16 ABCD is parallelogram. P is a point on AD such that  $AP = \frac{1}{3} AD$  and Q is a point on BC such that  $CQ = \frac{1}{3} BC$ . Prove that AQCP is a parallelogram.

Marks (3)

Q 17 In the figure given below, triangle ABC is right – angled at B. Given that AB = 9 cm, AC = 15 cm and D, E are the mid – points of the sides AB and AC respectively, calculate the area of trapezium DECB.

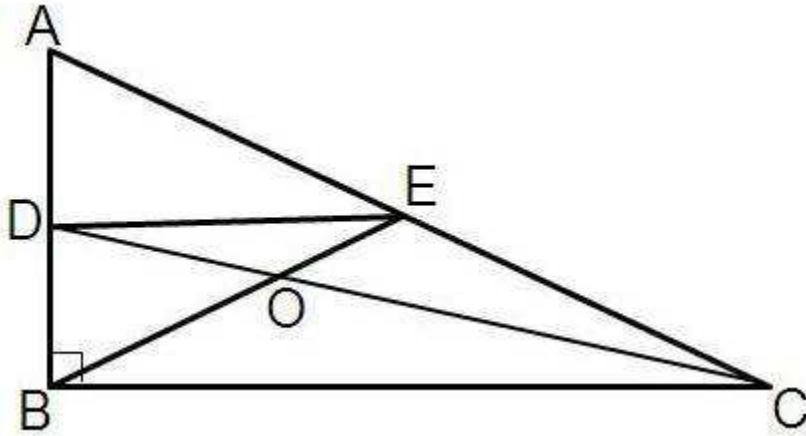

Marks (3)

Q 18 ABCD is a rhombus. AD is produced to E so that DE = DC and EC produced meets AB produced in F. Prove that BF = BC.

Marks (4)

Q 19 In a quadrilateral ABCD, CO and DO are the bisectors of  $\angle C$  and  $\angle D$  respectively. Prove that

$$\angle COD = \frac{1}{2}(\angle A + \angle B)$$

Marks (4)

Q 20 AD is the median of  $\triangle ABC$ . E is the mid point of AD. BE produced meet AC at F. Show that  $AF = \frac{1}{3}AC$ .

Marks (4)

Q 21 Show that the quadrilateral formed by joining the mid point of the consecutive sides of a rectangle is a rhombus.

Marks (4)

Q 22 P is the mid-point of side AB of a parallelogram ABCD. A line through B parallel to PD meets DC at Q and AD produced at R. prove that  $AR = 2BC$ .

Marks (4)

Q 23 P,Q,R are, respectively, the mid points of sides AB, BC and CA and of a triangle ABC. PR and AQ meet at X. BR and PQ meet at Y. Prove that  $XY = \frac{1}{4} AB$ .

Marks (4)

Most Important Questions

Q<sub>1</sub> The angle of a quadrilateral are respectively  $100^\circ, 90^\circ, 95^\circ$ . Find the fourth angle.

In a quadrilateral ABCD, the angles A,B,C and D are in the ratio 1:2:3:4.

Q<sub>2</sub> Find the measure of each angles of the quadrilateral.

Q<sub>3</sub> The sides BA and DC of a quadrilateral ABCD are produced as shown in fig. Prove that  $a + b = x + y$ .

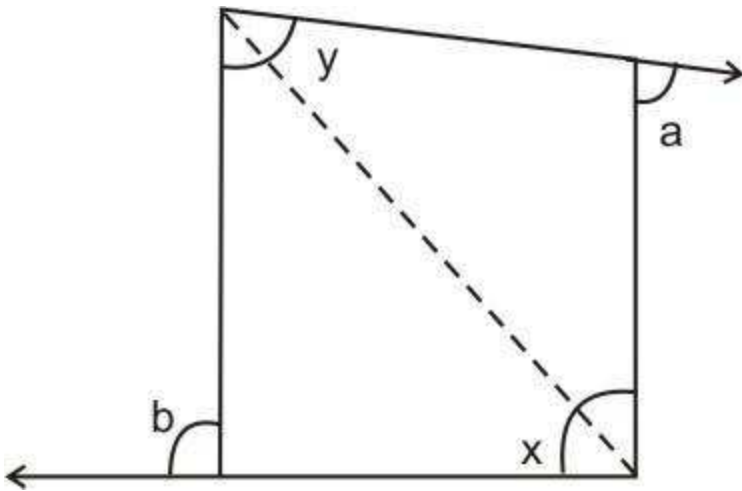

Q 4 The angles of a quadrilateral are in the ratio 3 : 5 : 9 : 13. Find all the angles of the quadrilateral.

Q 5

In a quadrilateral ABCD, AO and BO are the bisectors of  $\angle A$  and  $\angle B$  res

Prove that  $\angle AOB = \frac{1}{2}(\angle C + \angle D)$ .

Q 6 In a parallelogram ABCD, prove that sum of any two consecutive angles is  $180^\circ$ .

Q 7

In a parallelogram ABCD,  $\angle D = 115^\circ$ , determine the measure of  $\angle A$  and  $\angle B$ .

Q 8 In the given figure, ABCD is a parallelogram. Compute the values of x and y.

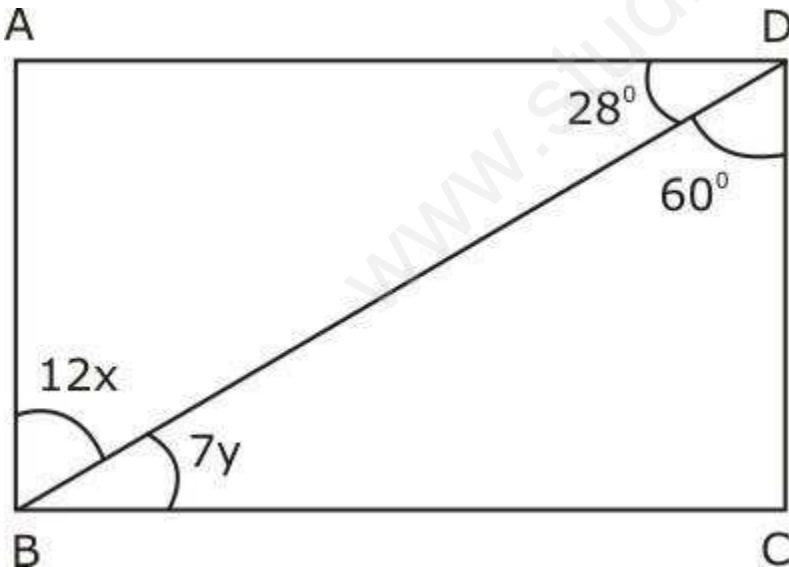

Q 9 In the given figure, AN and CP are perpendicular to the diagonal BD of a parallelogram ABCD.

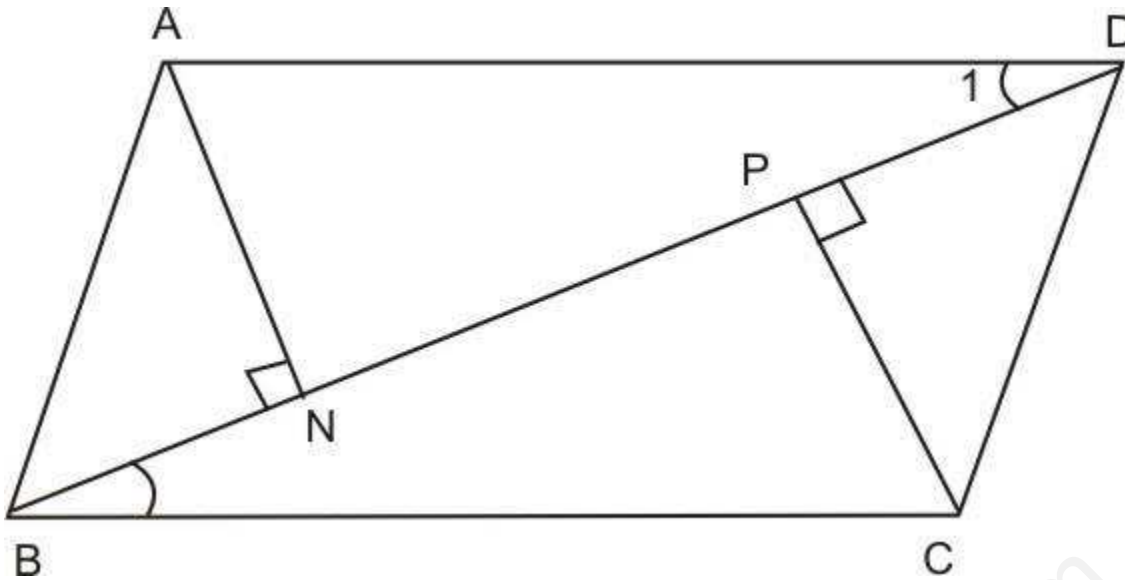

Prove that :

- (i)  $\triangle ADN \cong \triangle CBP$
- (ii)  $AN = CP$

If ABCD is a quadrilateral in which  $AB \parallel CD$  and  $AD = BC$ ,  
 Q 10 prove that  $\angle A = \angle B$ .

Q 11 In the given figure, find the four angles A, B, C and D in the parallelogram ABCD.

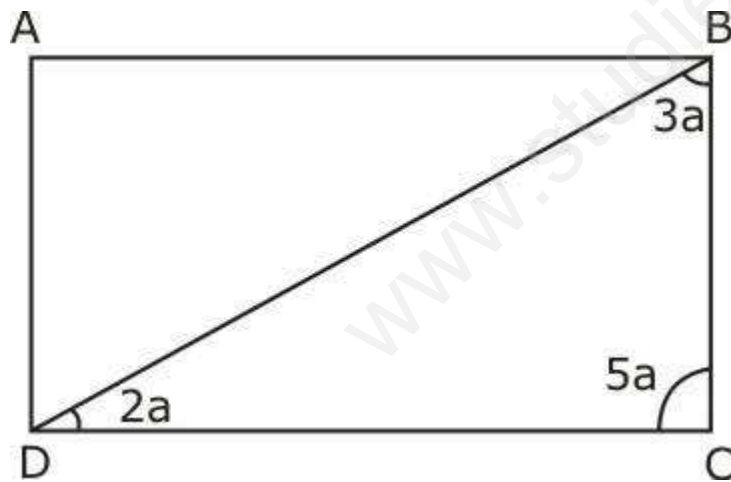

Q 12 In the figure given below, find all the angles of triangle BCD.

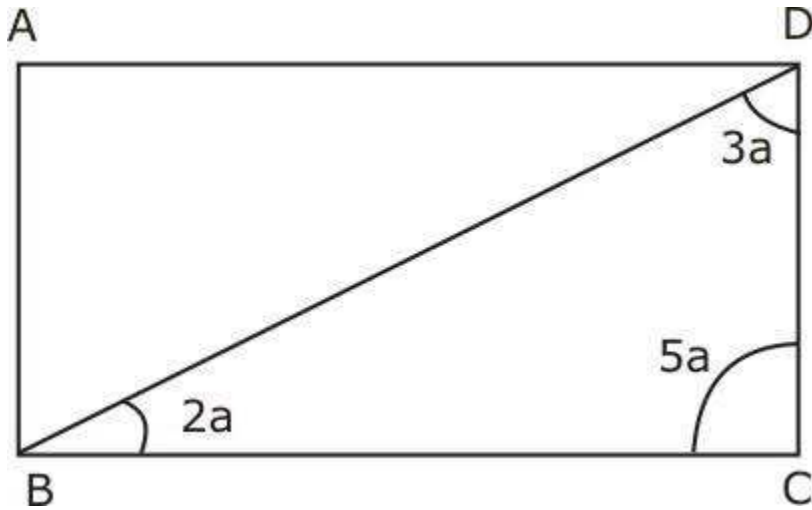

Q 13 Prove that angle bisectors of a parallelogram form a rectangle.

Q 14 AB and CD are the two parallel lines which are cut by a transversal l in point X and Y respectively. The bisectors of interior angles intersect in P and Q. form a parallelogram. Is it a rectangle?

Q 15 ABCD is a Rhombus AD is produced to E so that DE = DC and EC produced meets AB produced in F. prove that BF = BC.

Q 16 In a quadrilateral ABCD, CO and DO are the bisector of  $\angle C$  and  $\angle D$  respectively. Prove that  $\angle COD = \frac{1}{2}(\angle A + \angle B)$

Q 17 ABC be an isosceles triangle with AB = AC and let D, E, F are the mid-points of BC, CA and AB respectively. Show that AD perpendicular to EF and AD bisector of EF.

Q 18 In triangle ABC, AD is the median through A and E is the mid-point of AD. BE produced meets AC in F prove that AF = 1/3 AC

Q 19 Show that the quadrilateral formed by joining the mid point of the consecutive sides of a rectangle is a rhombus.

Q 20 ABCD is parallelogram. P is a point on AD such that AP = 1/3 AD and Q is a point on BC such that CQ = 1/3 BP. Prove that AQCP is a parallelogram.

Q 21 In a triangle ABC median AD is produced to X such that AD = DX. Prove that ABXC is a parallelogram.

Q 22 P is the mid-point of side AB of a parallelogram ABCD. A line through B parallel to PD meets DC at Q and AD produced at R. prove that AR = 2BC.

Q 23 P, Q, R are, respectively, the mid points of sides BC, CA and AB of a triangle ABC. PR and BQ meet at X. CR and PQ meet at Y. prove that XY = 1/4 BC